

Technics

Digital Control Receiver
Cassette Player

CQ-R9350EU/EC

Operating Instructions

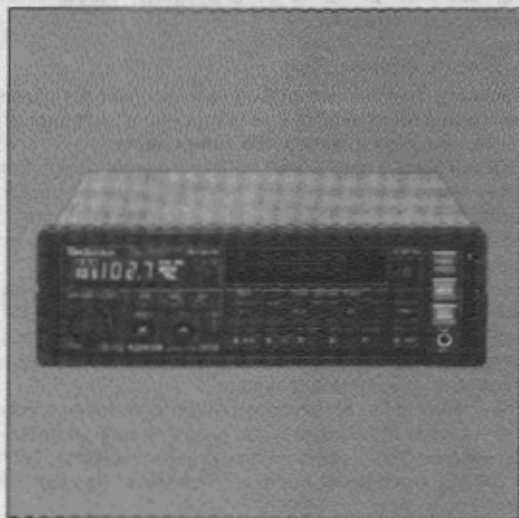

Before using this unit, carefully read these operating instructions and the enclosed suggestion for safety.

Thank you for purchasing the CQ-R9350EU/EC.
For optimum performance and safety, please read these instructions carefully.

Dear Stereo Fan

Technics, The Science of Sound, welcomes the challenge of new audio technologies and brings you a multitude of world-renowned, high-quality audio components.

Like our stereo high-speed editing cassette decks, Computer Drive New Class A receivers, quartz drive linear tracking turntables, and revolutionary Honeycomb Disc speakers.

All are backed by our time-honored commitment to imagination, value and quality.

Technics captures the power of new ideas and turns them into realities — with digital Compact Disc players that bring the search for perfect sound to fruition. And A/V receivers that can integrate both audio and video technologies to forever alter the home entertainment system.

The Technics list of advanced audio components continues. From digital PCM processors, quartz tuners and preamps to the world's first touch-sensitive graphic equalizer, Technics is a shining example of audio technology at its best—ready to take you to new dimensions in sound.

Location of Serial Number

"The model number and serial number of this product can be found on the bottom cover. Please write these numbers in the spaces, below, and retain this booklet for future reference, and as a permanent record of your purchase to aid identification in the event of theft."

Model No.: _____ Serial No.: _____

Contents

Location of Serial Number	2
Before Use	2
Suggestions for Safety	3
Operation of Controls	4
Main Controls	4
Unit Initial Setting	6
Listening to Radio Broadcast	8
About FM Reception	11
Listening to Cassette	12
TPS Operation	16
Theft Safety Device	17
About Cassette Tapes	19
Maintenance	19
Pre-Fader Switch	20
CD Input Jack	20
Troubleshooting Guide	21
Product Service	25
Accessories	25
Installation and Wire Connections	25
Fuse	25
Specifications	26

Before Use

Before use, make sure to press eject button.

- In some cases, cassette holder will be locked by the vibration during transportation.
After wiring connections and installation are completed, turn on the power and press the eject button then tape deck will be ready for use.
- Do not insert cassette until all wiring connections are completed. This model is equipped with an electronic eject system. Cassette will not eject when power is off.

Suggestions for Safety

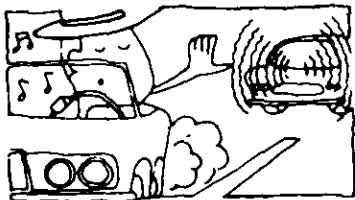

VOLUME LEVEL

For your driving safety, keep the volume level low enough to be aware of road and traffic conditions.

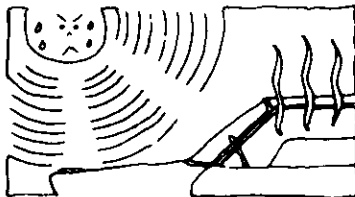

CAR VENTILATION

If your car is parked for several hours in direct sunlight, the temperature inside the car may become very high. It is advisable to drive the car and give the interior a chance to cool down before switching the unit on.

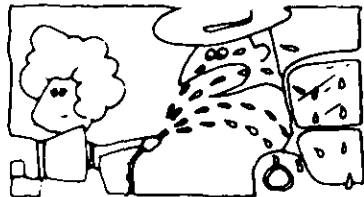

CAR WASHING

To avoid electrical shorts which may cause fire, or other damage, do not expose this equipment (including the speakers and tape) to water or excessive moisture.

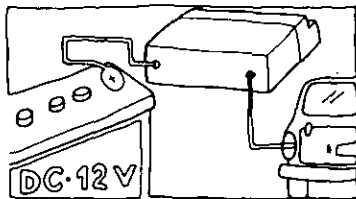

POWER SUPPLY

This equipment is designed to be used in automobiles having 12-Volt negative ground battery system.

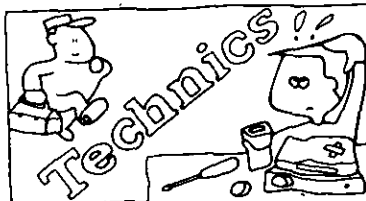

SERVICE

This unit is made of precision parts. Do not attempt to disassemble or adjust any parts. For repair, please consult your nearest Technics Service-center.



TAPE MECHANISM

Keep magnets, screwdrivers and other metallic objects away from the tape mechanism and tape head.

Operation of Controls

Main Controls (Radio/Tape Operation)

Volume Control (VOL)

Progressive rotation increases radio or tape player volume.



MIN MAX

Balance Control

(PULL LOCK BAL)

Pull the knob and lock it in position and turn it clockwise or counterclockwise until sound from the right and left speakers is about equal from your listening position.



RIGHT

PULL LOCK
BAL & TURN

After adjusting, depress the knob in.

Fader Control (FADER)

Adjust for best sound balance between the front and rear speakers.

This control is effective only when 3 or 4 speakers are installed.

FRONT



REAR



Power Switch (POWER)

Press this button to switch the power on. The LCD display shows the radio frequency in radio mode, or the tape direction indicator in tape mode. To switch the power off, press the button again.

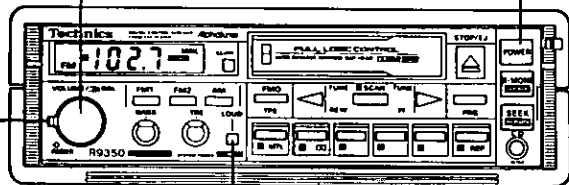
NOTE: The power switch is always illuminated when the car's ignition key is turned to "ACC" position regardless of whether the unit is on or off.



Loudness Button (LOUD)

This control is devised to compensate human hearing deficiency when volume is low. Switch on the loudness when listening at low volume; and when listening at high volume, switch off the loudness.  ON  OFF

Main Controls (Radio/Tape Operation)

Radio Frequency/Tape Direction LCD Display

The LCD display shows the radio frequency, tuning mode (MNL or SCAN), T-CALL mode and tape direction.

Illumination Button (ILLUMI)

This unit is equipped with either white or green illumination. By pressing this button, it will allow you to select the color you prefer.

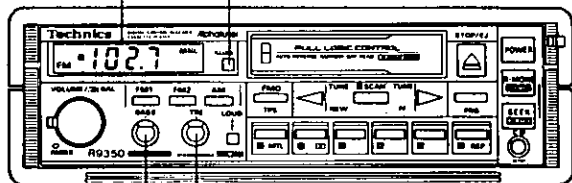

Treble Control (TRE)

Turn to the left or right for the desired treble tone.

Bass Control (BASS)

Turn to the left or right for the desired bass tone.

Unit Initial Setting

- For safety reasons, do not perform this section while driving your car. The built-in microprocessor has a very limited time to set and careful attention is needed on your part.
- This section can be adjusted during radio mode. Do not insert cassette tape.
- The step-by-step initial setting instructions below must be observed correctly.

STEP 1: INTRODUCTION

F·CALL activates the following functions:

1. Tuning Mode (MNL or SCAN) See Step 2.
2. Tuner Call Mode (T·CALL) See Step 3.

- F·CALL means Function Call.
- F·RUN means Function Run.

At first use, the LCD display shows the following mode, when the power switch is pressed "on".

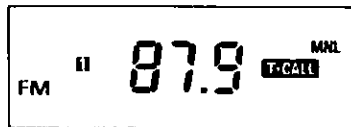

LCD display at the first use.

STEP 2: SELECTION OF TUNING MODE ("MNL" OR "SCAN")

1. At the first use, the tuning mode is preset at "MNL" position. The "MNL" indicator appears on the LCD display.
2. To change the tuning mode from "MNL" to "SCAN", press the F·CALL button "repeatedly" until the "MNL" indicator blinks, and then immediately go to item 3 while the "MNL" indicator is blinking.

NOTE: The F·CALL button can not be operated if any of SEEK, TUNE (up/ down scan) or P·SCAN is operating.

3. Press the F·RUN button once. The "SCAN" indicator blinks for several seconds.
After that, "SCAN" tuning mode is selected.
4. To change the tuning mode from "SCAN" to "MNL", repeat items 2 and 3. But "MNL" and "SCAN" are transposed.

NOTE: After the tuning mode is selected, the F·RUN button will operate as SEEK tuning function.

- For manual and scan tuning operations, please refer to page 9.

Unit Initial Setting (Cont'd.)

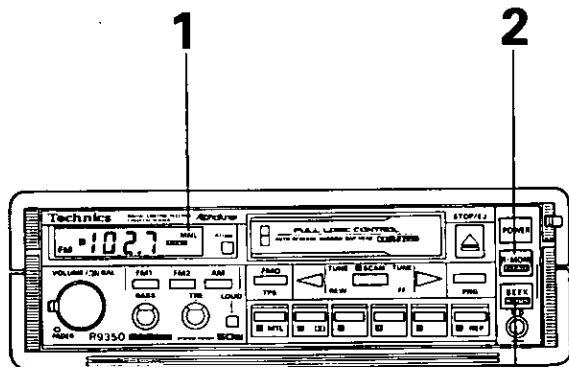

STEP 3: TUNER CALL MODE (T·CALL)

When the "T·CALL" indicator appears on the LCD display, it means that you can listen to the radio during the REW (rewind) or FF (fast forward) operation.

1. At the first use, the tuner call is preset at on position ("T·CALL" indicator appears on the LCD display).
 2. To cancel tuner call mode, press the F·CALL button "repeatedly" until the "MNL" or "SCAN" indicator blinks. Then press the F·CALL button again, and immediately press the F·RUN button once and the "T·CALL" indicator goes out. The tuner call circuit is switched off.
 3. Pressing the F·RUN button again within 10 seconds will bring you back to T·CALL mode, and vice-versa.
Otherwise, repeat item 2 for T·CALL mode.
- For tuner call mode operation, please refer to page 12.

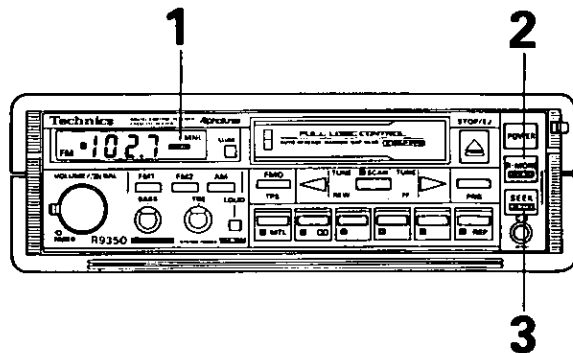

Listening to Radio Broadcast

"1" indicates that the FM1 band selector is pressed.

"2" indicates that the FM2 band selector is pressed.

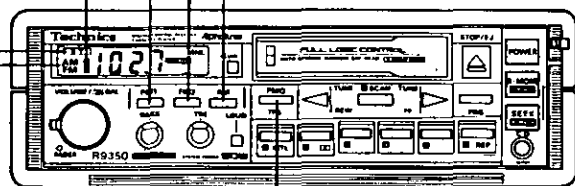

AM/FM Band Indicator

FM Stereo Indicator (ST)

Shows on the LCD display when the FM radio program is being received in "FM Stereo".

Band Selector (FM/AM)

FM1: To select FM1 press this button and the FM radio frequency and selected band "1" shows on the LCD display.

FM2: To select FM2 press this button and the FM radio frequency and selected band "2" shows on the LCD display.

AM: To select AM, press this button and the AM radio frequency shows on the LCD display.

FM Optimizer Button (FMO)

At the first use, the FMO button is at "on" position. The red light on the button lights up.

If "static" noise is heard continuously while listening to FM radio in fringe areas (weak signal areas), press the FMO button to on. The red light on the FMO button will light up. Switch to off by pressing it again.

Listening to Radio Broadcast (Cont'd.)

Up/Down Manual Tuning Buttons (TUNE)

Set the tuner to "MNL" tuning mode.

By pressing the ► or ◀ button, you can move up and down the frequency range.

NOTE: When you hold the button for more than half a second, the tuning frequency will count up or down rapidly. The tuning will stop instantly as soon as you release the button.

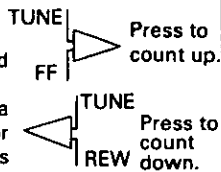

"MNL" or "SCAN"
Mode Indicator

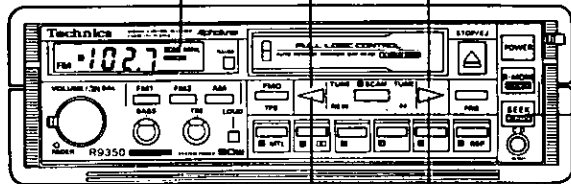

**BEFORE OPERATING THIS SECTION
READ THE INSTRUCTIONS ON PAGE
6 STEP 2 "SELECTION OF TUNING
MODE ("MNL" OR "SCAN")".**

Up/Down Scan Tuning Buttons (TUNE)

Set the tuner to "SCAN" tuning mode.

Up (►) or down (◀) scan tuning is possible.

To automatically tune stations, press up or down button and the unit will begin to search upwards or downwards from the currently displayed frequency. When a station is located, the frequency is held for about 5 sec. (the radio frequency is blinking on the LCD display), and then the unit will continue to search for the next station and so on.

If you desire to keep the station that has been found, press up (►) button to stop upwards scanning or press down (◀) button to stop downwards scanning.

NOTE: During up/down scan tuning, the F·CALL button can not be operated.

Seek Tuning Button (SEEK)

Each time the button is pressed, the seek tuning is automatically done and will stop on the next station.

NOTE: The seek tuning will count up only.

Listening to Radio Broadcast (Cont'd.)

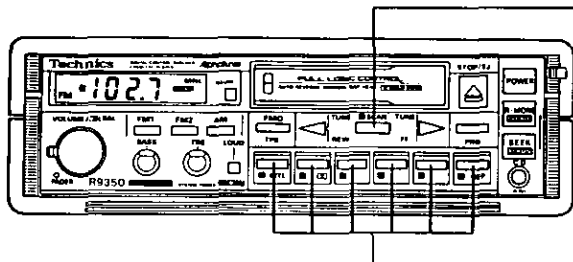

Preset Scan Button (P · SCAN)

Press the P · SCAN button and the unit begins to search the stations being previously programmed into the preset station selectors (1–6). For FM reception, twelve (12) preset stations, six (6) for FM1 and six (6) for FM2, respectively, can be scanned continuously; and the FM1 or FM2 indicator is shown on the LCD display accordingly. Each preset station is scanned for several seconds and the radio frequency is blinking on the LCD display. The red light on the scanned preset station selector button will light up. When reaching the desired preset station, press the P · SCAN button again, or press the preset station selector itself.

NOTE: During preset scan tuning, the F · CALL button cannot be operated.

To Set the Preset Station (Preset Station Selectors (1-6))

Six (6) stations for AM, FM1 and FM2, respectively, can be preset in the built-in electronic memory circuit on this unit. Each preset station selector can select one (1) station on AM and one (1) station each on FM1 and FM2. Thus, the six (6) preset station selectors can be used to select a total of eighteen (18) stations.

1. Tune in to the desired station either by scan, seek or manual tuning.
2. Hold one of the preset station selectors in for about 2 seconds. (This will activate the memory circuit to preset the desired station.) Release the preset station selector after you hear the radio again. The station frequency being displayed will blink once to show that the memory has been set. The red light on each of the preset station selector will light up, if the selector is pressed.

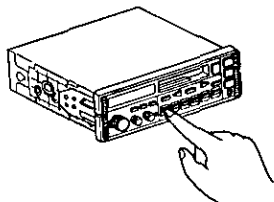

NOTES:

1. Memory will not activate when the preset station selector is "hurriedly" released.
2. If any of these preset station selectors is accidentally pressed and held for several seconds (about more than 2 sec.), the previously "preset" station will be erased; instead, a different station will be registered into that memory circuit in which the band is playing.

About FM Reception

FM Radio signals

FM broadcasts are transmitted at a very high frequency (VHF) and will not bend but travel in a straight line. Tall buildings, mountains, or other obstructions may cause partial "shadows" due to loss of signal and cause momentary "hisses" in FM reception. (The best reception occurs in a good, unobstructed area.) Reflected signal from the obstructions also occasionally cause interference (multipath distortion).

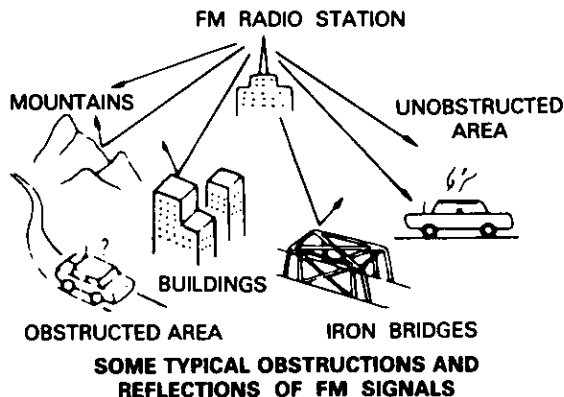

FM Optimizer

When receiving FM while driving, the FM signals will vary depending on the distance from the transmitting station. As a result, good, clear and noise-free FM reception may be practically difficult especially in fringe areas (weak signal areas). In order to obtain clean and noise-free reception under these circumstances, this new FM Optimizer circuit is provided. FMO also provides gradual switchover from stereo to monaural reception. Furthermore, FMO automatically cuts off disturbing "treble noise" during monaural-switched reception. This FM Optimizer circuit functions to keep FM reception in optimum condition.

INQ (Impulse Noise Quieting) Circuit

One of the most frequently encountered conditions in an FM receiver is the reception of pulse noise. Hearing a kind of "put put" sound reproduced by a car radio when a motor-cycle approaches the car is a typical case of pulse noise. Unfortunately, automobiles have a variety of pulse noise sources. These include the engine spark plugs, etc. In order to reduce this unpleasant noise, this unit is equipped with an INQ circuit.

Listening to Cassette

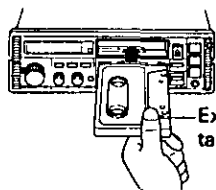

Exposed
tape side

Cassette Slot

- Press the power switch to turn on the unit.
Insert cassette with exposed tape side facing to the right. Push inward until the mechanism captures the cassette. Playback starts automatically when the cassette tape is inserted. The radio will come back on automatically when the cassette is ejected.
- Reel Rotation Detector
If the tape has a slack in the cassette, the reel rotation detector is activated to reverse the tape being played. When the tape is reversed "repeatedly", it is an indication that the tape may be defective.

Tuner Call Mode (T · CALL)

- Set the unit to "T · CALL" mode. The "T · CALL" indicator is shown on the LCD display. Please refer to Step 3 "Tuner Call Mode" on page 7.
- During REW or FF operation mode, the previously tuned radio station can be listened to. The LCD display shows the radio frequency. At the end of REW or FF operation, the radio will stop playing and tape play will resume.
- T · Call mode will not work when TPS button is switched on.

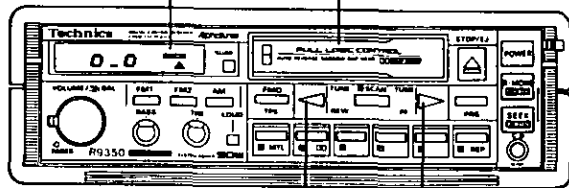

Rewind/Fast Forward Buttons (REW/FF)

Make sure the TPS button is not pressed. Otherwise, the TPS function will operate.

- Press the FF button for fast forward. When the tape reaches its end, Auto Reverse will operate and play back the opposite side of the tape.
- Press the REW button for rewind. When the tape is fully rewound, tape plays back again the same side of the tape.
- To stop REW or FF operation, press the STOP/EJ button. Then the tape play will resume from that position.

NOTES:

1. The REW or FF button should not be pressed before the tape has started playback.
2. If the TPS button is switched on during REW or FF operation, the tape will stop and starts playing the beginning of the nearest music program. See explanation on "TPS Button" on page 15.
3. The tape direction indicator (◻-◻▲ or ◻-◻▼) will blink faster during REW or FF operation (if T · CALL is at "off" position).

Listening to Cassette (Cont'd.)

Tape Program Selector (PRG)

Press this button if you want to change the direction of tape play. The tape direction indicator $\square-\square \blacktriangle$ or $\square-\square \blacktriangledown$ shows on the LCD display. If the button is not pressed, tape direction will change automatically at the end of the tape (AUTO REVERSE system).

Tape Direction Indicator ($\square-\square \blacktriangle$ or $\square-\square \blacktriangledown$)

The tape direction indicator appears on the LCD display when the cassette is inserted.

- $\square-\square \blacktriangle$: Indicates the top side of the cassette is being played.
- $\square-\square \blacktriangledown$: Indicates the bottom side of the cassette is being played.

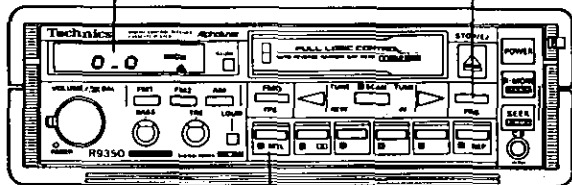

Metal Tape Selector (MTL)

Switch on the button for playing metal or CrO₂ tape. The red light on the button will light up. Switch off the button for playing normal tape. The red light goes off.

NOTE: This switch serves as an equalizer for reproduction of tape recorded using "Metal" or CrO₂ tape with 70 μ s equalization, or tape recorded using "normal" tape with 120 μ s equalization. Wrong setting will cause high frequency imbalance.

Listening to Cassette (Cont'd.)

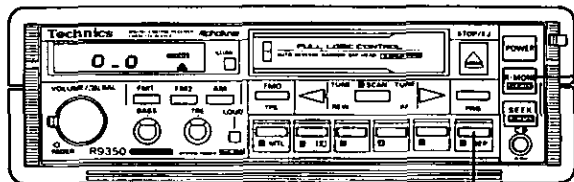

Radio Monitor Button (R-MONI)

During tape playback, if you want to listen to the radio momentarily, simply press the R-MONI button. Tape playback will stop (pause mode) and the radio can be heard. To resume tape playback, press the R-MONI button again.

NOTE: At "radio monitor" mode, tuning in to another radio station can be made.

- Radio monitor mode will be cancelled when power is switched off or when a CD player is connected to this unit.

In the following conditions, REPEAT may not perform properly when:

- The blank space between recorded programs is less than 3 seconds.
- The cassette tape has an interrupting conversation recording. (There may be more than 3 sec. blank space in that portion of the tape.)
- There is a portion of the tape where the sound level is particularly low or there is no sound.
- The remaining playing time of a song is less than 10 sec. preceding the beginning of the next song before the REPEAT function is turned on.

Repeat Button (REP)

Press this button to repeat the same music you are now listening to.

- Press the REP button and the red light on the button will light up. After finishing the music just listened to, the rewind starts automatically until the beginning of music, and the same music starts playing again. When you want to cancel repeat operation, press the REP button again. The red light goes off.

Listening to Cassette (Cont'd.)

TPS Button (TPS)

The red light on the button lights up when the TPS button is switched on.
For further details on the TPS button, refer to instructions on next page.

Stop/Eject Button (STOP/EJ)

To stop playing, press this button. The cassette will pop out for removal, and the radio will be heard again.
NOTES:

1. If power is switched off before the STOP/EJ button is pressed, the cassette will not eject. Switch on the power again and press the STOP/EJ button to eject the cassette.
2. The cassette tape should always be removed from the cassette slot when not in use.
3. If the cassette tape would not eject due to some obstructions, the unit will switch to "radio" mode automatically. In this case, remove any obstruction and press the STOP/EJ button again. Then cassette tape will eject normally.

Dolby noise reduction manufactured under license from Dolby Laboratories Licensing Corporation.
"DOLBY" and double-D symbol  are trademarks of Dolby Laboratories Licensing Corporation.

Dolby Noise Reduction Button (NR)

Press the button on for playback of tape recorded by the Dolby Noise Reduction System. The red light on the button will light up.
Press button again (red light goes off) for playback of tape not recorded by the Dolby Noise Reduction System. Cassette tapes not recorded with Dolby NR do not benefit from use of Dolby NR during playback.
Using the Dolby NR System on non-Dolby-encoded tape causes high frequency imbalance.
NOTE: The Dolby NR circuit will not operate in radio mode.

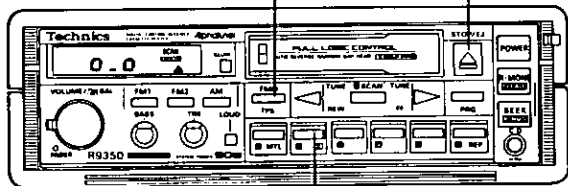

TPS Operation (TPS)

TPS Button (Tape Program Sensor)

Press this button to find the starting point of each program in a prerecorded music tape. The quiet space between programs (must have at least a 3 sec. gap) can be sensed by the tape program sensor (TPS) circuit. If TPS is not required, press the TPS button again and the light goes off.

NOTE; Most commercially available music cassette tapes are suitable for TPS system.

How to operate the TPS:

Press the TPS button and the red light on the button comes on.

Forward TPS:

Pressing the FF button will play the beginning of the next music.

Rewind TPS:

Pressing the REW button will replay the beginning of the music just listened to.

NOTES:

1. The TPS system will be operated if the TPS button is switched on even after the fast forward or rewind operation is already in process.
2. TPS system will only operate after a lapse of about 1.5 seconds from the start of playback.

Tapes not suitable for TPS operation:

The TPS circuitry may not function properly for tapes described below, causing tapes to stop midway through a program or to overrun the space between programs.

1. Tapes which contain intermittent sound program, such as conversations, lectures, news, pianissimo-featured classical music, or music that includes many silent or mute passages.
2. Tapes which have a very short time interval between recorded programs.
3. Tapes which have a high level of noise or hum between programs.
4. Tapes which have a particularly low recorded level.

Theft Safety Device

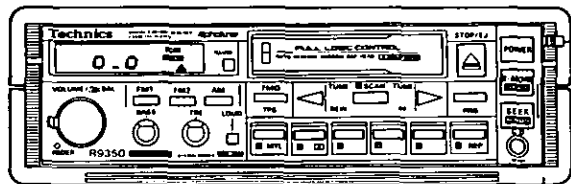

KEY HOLE:

If the key (supplied with this unit) is inserted into this key hole, the safety lock will be released, and the unit can be removed from its bracket.

For more details, please refer to "How to Remove and Install the Unit" on this page.

HANDLE:

It is used for pulling the unit from its bracket and carrying it out anywhere. **DO NOT PULL THE HANDLE AND REMOVE THE UNIT BEFORE RELEASING THE SAFETY LOCK.**

● How to Remove and Install the Unit

REMOVAL:

1. Switch off the power.
2. Insert the key into the key hole (Fig. 1, ①) completely until the safety lock is released.
As a result, the handle will be slightly lifted upwards. (Fig. 1, ②)
3. Remove the key and lift the handle. Remove the unit from its bracket by pulling the handle firmly. (Fig. 1, ③)

Note: If the handle is pushed back to its original down position, the safety lock will Lock on the bracket again. In this case, repeat step 2 above.

INSTALLATION:

Insert and push the unit into its bracket until the back of es-cutechon reaches the bracket. The unit will be locked in automatically.

Theft Safety Device (Cont'd.)

NOTES:

- Before removing the unit out of its bracket, make sure to switch off the unit.
- It is very dangerous to operate the unit with the safety lock is released. If there is such an occurrence, replace the handle back to its original down position or remove the unit and replace it back firmly to its bracket.
- After operating the unit for a long period of time, it will become very hot especially the left side. Please be aware of this and pay careful attention.
- The unit has no water-proof capability. Therefore, do not expose the unit to water, or excessive moisture.
- Do not abuse the unit by shocking, dropping, or swing the unit while carrying it with the handle.
- For safety reasons, do not remove the unit from its bracket or preset any radio function while driving your car.
- Do not lose the key. Keep it together with your car's ignition key.

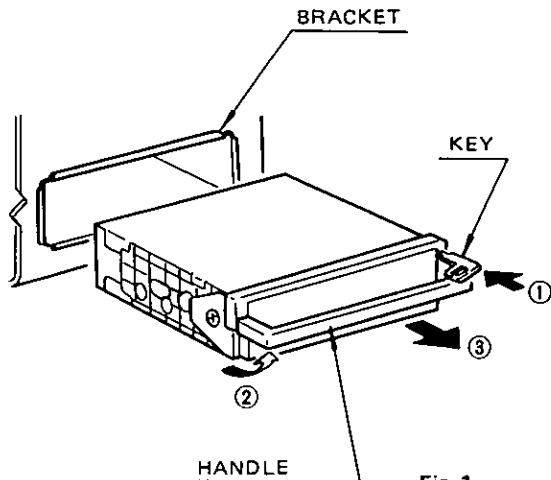

Fig. 1

About Cassette Tapes

- Avoid using tapes longer than C-90 (90 min.). Such tapes can easily be stretched or broken.
- Before using, check cassette for tape slack. Loose tape may become tangled in pinch rollers and may damage tape or unit. Use a pencil or similar object to tighten tape.
- Avoid storing tape in places of extreme temperature or humidity. Do not leave tapes in direct sunlight.
- Avoid touching the tape surface or exposing tapes to strong magnetic fields such as speakers, motors, transformers, etc.
- Keep tapes free from dust or dirt. Store tapes in the case when possible and keep in a cool dry place.
- To obtain optimum performance when using metal tapes be sure to press the metal switch (MTL) to the "on" position.

Maintenance

● TAPE HEAD CLEANING

The tape head in the cassette player mechanism can accumulate dust and tape residue, causing poor or wavering sound.

To obtain optimum performance, clean the tape head after every 10 hours of use.

To clean the tape head, use a commercially available head cleaning tape.

● EXTERIOR CLEANING

To clean the exterior of this unit (escutcheon and chassis), use a soft cloth to wipe the surface. Do not use benzine, thinner, or any other type of solvent.

Pre-Fader Switch

The PRE-FADER SWITCH is located on the bottom of this unit.

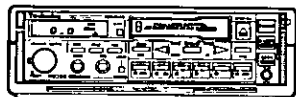

PRE-FADER SWITCH

PRE-FADER

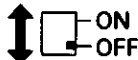

This switch makes the fader control effective if an additional graphic equalizer and/or power amplifier are connected to the PRE-AMP (Low-Level) OUTPUT CONNECTOR.

In the "OFF" position, the fader controls the front and rear speakers' high-level output. However, preamp-out (low-level) will not be affected if it is also connected.

In the "ON" position, the fader controls the front speakers' high-level output and rear speakers' preamp-out (low-level) output. There will be no audio output at the rear speakers' high-level output connections. Therefore, do not attempt to connect to it.

CD Input Jack

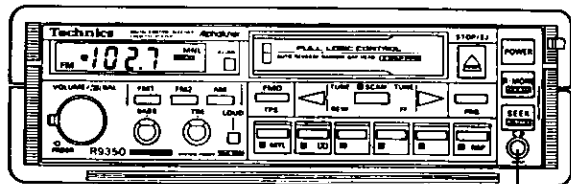

CD Input Jack (CD INPUT)

- (1) The CD INPUT jack is used for connection with a portable CD player or other auxiliary equipment.
- (2) The volume control of this unit should be in the minimum level position when plugging in and out the auxiliary equipment, or when turning the CD player or auxiliary equipment "on" and "off".
- (3) Never connect an auxiliary equipment having a signal level of more than 2V (RMS).
- (4) The auxiliary equipment has priority over that of the cassette tape playback or radio.
- (5) Be sure to unplug the auxiliary equipment from the CD INPUT jack after using it.

NOTE. The volume control of the portable CD or other auxiliary equipment should be adjusted to the appropriate listening level (not so loud) position.

Troubleshooting Guide

Before requesting service for this unit, check the chart below for a possible cause of the problem you are experiencing. Some simple checks or a minor adjustment on your part may eliminate the problem and restore proper operation.

If you are in doubt about some of the check points, or if the remedies indicated in the chart do not solve the problem, refer to the directory of Matsushita Factory Servicenters (enclosed with this unit).

WHEN USING	PROBLEM	PROBABLE CAUSE	SUGGESTED REMEDY
Radio	No Sound	Cassette tape is inserted. The power was switched off.	Remove the cassette tape. Switch on the power.
	Poor Reception	Weak signal due to distance between your car and the radio station.	Switch on the FMO. Or tune in to another radio station.
		Antenna connection and its instal- lation was not done properly.	Check the antenna connection and its installation.

Troubleshooting Guide (Cont'd.)

WHEN USING	PROBLEM	PROBABLE CAUSE	SUGGESTED REMEDY
Radio	Memory setting can't be done.	The Battery Lead is disconnected.	Check the Battery Lead and its connection.
	Memory setting had vanished completely.	The battery is discharged.	Recharge the battery. Or replace the battery, if worn out.
		The battery cable is disconnected.	Secure the battery cable into the car battery.
		The battery has been replaced.	Charge the battery after the battery is replaced. All electronic memory previously set would fade out. Reset by following the previous instructions in this manual.
	Tuning and other programming modes (SCAN, MNL, T·CALL, etc.) cannot be performed.	The programming sequence was incorrect; such as the F·CALL and F·RUN sequence were wrongly done.	The tuner section is quite sophisticated due to employment of multi-function pushbutton switches. Please carefully read the instructions on pages 6 ~ 7 to obtain correct initial settings.

Troubleshooting Guide (Cont'd.)

WHEN USING	PROBLEM	PROBABLE CAUSE	SUGGESTED REMEDY
Cassette Player	No Sound	Cassette tape may be defective, or it may be caught on the head or the capstan shaft.	Replace or remove the cassette tape from the cassette slot.
		The R·MONI button is switched on.	Switch off the R·MONI button.
	Poor Playback	Dirty tape heads.	Clean the tape heads periodically.
Cassette Player	Distorted Sound	Cassette tape may be defective.	Replace the cassette tape with another one.
		Wrong settings of Dolby NR and Metal.	Set the Dolby NR and Metal to their appropriate positions.
Common	No Sound or Power	The Power Lead is not properly connected.	Check the Power Lead and its connection.
		The Ground Lead is not properly connected.	Check the Ground Lead and its connection.
		The Speaker Leads are not properly connected.	Check the Speaker Leads and their connections.
		The fuses in the Power Leads are blown out.	Replace the fuse(s) with the correct rating. See "Fuse" on this manual.

Troubleshooting Guide (Cont'd.)

WHEN USING	PROBLEM	PROBABLE CAUSE	SUGGESTED REMEDY
Common	No Sound or Power	The ignition switch is in "off" position.	Switch the ignition to the "ACC" position. Do not operate the unit for a long time in "ACC" position. The battery might be discharged.
		Other wirings are loose or insufficient.	Check all wirings and their connections.
		The Volume Control is in the minimum level position.	Set the Volume Control to the proper level.
	Inverted Sound	The left/right speaker connections are inverted.	Check the Speaker Leads and their connections.
	Sound comes from one speaker only	One of the Speaker Leads is disconnected.	Connect the Speaker Lead correctly.
		The Balance Control is in one-side position.	Adjust the Balance Control.

Product Service

■ Warning concerning removal of covers

This unit should be serviced by qualified technicians only.

No service information is provided for customers.

Your product is designed and manufactured to ensure a minimum of maintenance. However, should your unit ever require service a nationwide system of factory servicenters (listed) and AUTHORIZED INDEPENDENT SERVICENTERS is maintained to support your product's warranty.

Accessories

- Installation instructions 1
- Warranty card 1
- Directory of authorized servicenters 1
- Installation accessories 1 set

Fuse

Be sure to use a fuse of specified rating (5A, 3A) when replacing a blown fuse.

Fuses rated at higher capacity, use of any substitute, or connection without a fuse may result in fire hazard or damage to the unit.

If the replacement fuse fails, contact your nearest authorized Technics Service Center.

Installation and Wire Connections

- For installation and Wire Connection instructions, refer to the "Installation Instructions" enclosed.
- For installation of an additional Power Amplifier other than Technics brand, a special adaptor might be required, and it is recommended to consult your Technics dealer.

Specifications

Power supply	: 12V DC (11V ~ 16V), test voltage 14.4V, negative ground
Maximum power output (total)	: 25W (per channel at 400Hz, volume control maximum)
"EIA" power output	: 10W 40Hz ~ 20kHz, at 1% THD
Tone action	: ± 10 dB at 100Hz and 10kHz
Loudness control	: +10dB at 100 Hz
Current consumption	: Less than 1.7A (at 0.5W)
Speaker impedance	: 4 Ω (4 Ω ~ 8 Ω available)
AM radio	
Frequency range	: 530kHz ~ 1,610kHz
Intermediate frequency	: 450kHz
Usable sensitivity (S/N 20dB)	: 30dB/ μ V (32 μ V)
Selectivity	: 40dB (± 10 kHz)
FM stereo radio	
Frequency range	: 87.9MHz ~ 107.9MHz
Usable sensitivity	: 13.2dBf (1.25 μ V) (75 Ω)
50dB quieting sensitivity	: 15.2dBf (1.6 μ V) (75 Ω)
Frequency response	: 20Hz ~ 15kHz, ± 3 dB
Capture ratio	: 1.5dB
Alternate channel selectivity	: 75dB
Stereo separation	: 42dB at 1kHz
Image response ratio	: 65dB
IF response ratio	: 100dB
Signal-to-noise ratio	: 70dB

Above specifications comply with EIA interim standard.

NOTE:

Specifications and the design are subject to possible modification without notice due to improvements.

Tape player	
Reproduction system	: 4-track, 2-program stereo
Tape speed	: 1-7/8"/sec. (4.76cm/sec.)
Fast forward time	: Less than 90sec. (C-60)
Rewind time	: Less than 90sec. (C-60)
Frequency response	: 30Hz ~ 17kHz, ± 3 dB (metal tape) 30Hz ~ 14kHz, ± 3 dB (normal tape)
Wow and flutter	: 0.09% (wrms)
Stereo separation	: 45dB at 1kHz
Signal-to-noise ratio	: 52dB (Dolby NR off) 62dB (Dolby NR on)
Pre-amplifier output voltage	: 0.6V (Ref. level; 0dB)
Dimensions	: 7"(W) X 5-7/8"(D) X 1-15/16"(H) (178mm X 150mm X 50mm)
Weight	: 3 lbs. 14 oz. (1.75kg)

"Dolby" and the double-D symbol are trademarks of Dolby Laboratories Licensing Corporation.

Memorandum

**Panasonic Company
Division of Matsushita Electric Corporation
of America**

1 Panasonic Way, Secaucus, N.J. 07094

Matsushita Electric of Canada Ltd.

5770 Ambler Drive.
Mississauga, Ontario, L4W 2T3.

Panasonic Hawaii, Inc.

91-238 Kauhū St. Ewa Beach, P.O. Box 774
Honolulu, Hawaii 96808-0774

**Panasonic Sales Company
Division of Matsushita Electric
of Puerto Rico, Inc.**

Avenue 65 de Infantería, Km 9.7
Victoria Industrial Park
Carolina, Puerto Rico 00630